

Mit Sicherheit gut aufgehoben.



EN

General information
INSTALLATION AND OPERATING INSTRUCTIONS
for HTM TR40-01



TABLE OF CONTENTS

1. Notes on putting into operation and safe use
2. Technical specifications
3. Range of use
4. Putting the product into operation
5. Installation notes
6. Tips and help
7. Cleaning and care
8. Saving energy
9. Disposal
10. Guarantee



Please read the operating instructions first.

Dear Customer,

Please read the operating instructions carefully before you put the product into operation.

This high-quality product has been manufactured on modern machinery taking environmental aspects into account, and tested by a detailed quality check. Please follow the safety instructions for long and optimum function.

Keep the operating instructions for later reference. Please also read the other documents delivered with the product.

IMPORTANT NOTE:

**The manufacturing company reserves the right to make changes to the product!
Hartmann Tresore AG is not liable for damage caused by improper use.**

This product complies with the requirements of the following EU directives:

- **2006/95/EG (73/23/EEC)**
Directive relating to electrical equipment for use within certain voltage limits
- **2004/108/EG (89/336/EEC)**
Directive relating to electromagnetic compatibility
- **Delegated regulation (EC) Nr. 1060/2010**
Directive relating to energy labelling of household refrigerating equipment
- **(EG/643/2009)**
Directive relating to energy efficiency clauses

1 | NOTES ON PUTTING INTO OPERATION AND SAFE USE

General notes

- Never set the appliance up near sources of heat (e.g. radiator). Avoid direct sunlight.
- Set the appliance up on a safe level surface. Please note that the appliance has to be screwed to the substructure for installation of the optional sliding door fitting.
- The ambient temperature should be between 16 and 32 °C to achieve optimum appliance performance.
- Check the appliance for any defects and make sure all the accessories included are complete before putting it into operation.
- Allow the appliance to cool for 2 to 3 hours after switch-on before you fill it with food.
- We recommend that you disconnect your appliance from the power supply if you are not using it for a longer period.



WARNING! Non-observance of the safety instructions below can lead to danger for life and limb!

- This appliance must not be used by persons (including children) with reduced physical, sensory or mental capacities or a lack of experience and knowledge unless they are instructed about safe use of the appliance by a person responsible for their safety or are supervised during use.
- Never place any potentially explosive substances that contain combustible gases into the appliance.
- Suitable specialist personnel should connect the appliance to the power supply system. Use a power socket compliant with the current safety guidelines.
- Never touch non-insulated cables and wires.
- Repairs may only be carried out by specialists. Improper repairs are a source of significant hazard potential and lead to the guarantee being rendered invalid.

! PLEASE NOTE! Risk of damage!

- Compare the voltage available from the power supply with the voltage specification on the rating plate.
- Never cover the appliance's ventilation openings. If the appliance is installed in a cupboard or two appliances are set up next to one another, air circulation must always be guaranteed. Otherwise there is a risk of overheating **(see chapter 5)**!
- Avoid contact of the appliance surface with oils, greases and substances containing solvent.
- Never use any gaseous, fuel-containing or similar materials for cleaning **(see chapter 9)**.
- The shelves are made of glass. Handle them with appropriate care.

2 | TECHNICAL SPECIFICATIONS

1. shelves
2. inner door compartments (shelves)
3. door seal
4. temperature regulator

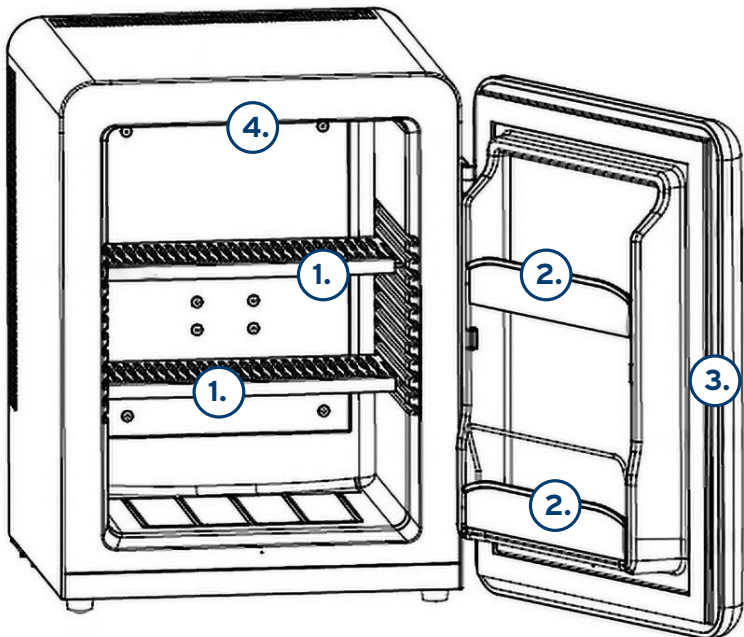

Sketch may differ from the product.

3 | RANGE OF USE

The appliance has been designed exclusively for use indoors, e.g.

- in hotels, bed & breakfast establishments or other accommodation facilities
- in business and offices



The appliance must not be used outdoors.

4 | PUTTING THE PRODUCT INTO OPERATION

- Please check whether the appliance shows signs of any defects.
- Install the appliance in accordance with section 5.
- We recommend screwing the appliance to a firm surface by the bases to prevent tilting.
- Plug the minibar plug into the socket.
- The temperature setting control is located on the top of the refrigerator inside.
- To regulate the internal temperature, set the rotary knob according to the ambient temperature or the intended use.
- The range of the temperature controller extends from position "0" to "3".

Controller inside

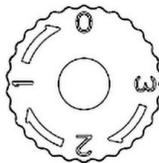

Control knob up
integrated in lamp

5 | INSTALLATION NOTES

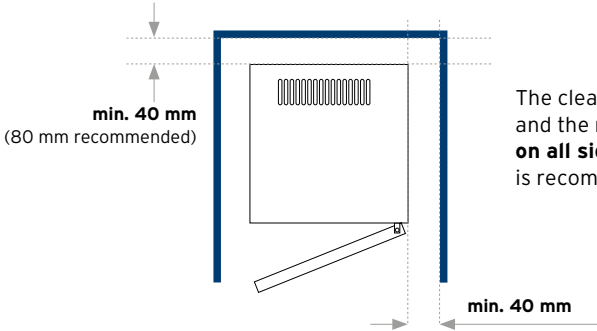

The clearance between the furniture walls and the minibar should be **at least 40 mm on all sides**. However, a **clearance of 80 mm** is recommended **at the back**.

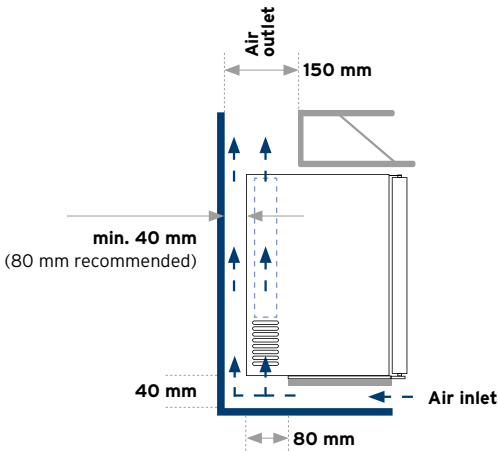

Minibars withdraw heat from the interior to cool it. This heat is discharged again via the back. For this reason, the air must be able to circulate freely around the minibar. To achieve this, **a free ventilation cross-section of at least 200 cm²** must be guaranteed during installation for inlet and discharge air. Generally speaking, the following applies: **The better the hot discharge air can be dissipated away from the minibar, the better its efficiency, i.e. energy consumption drops.** The inlet air for the minibar is supplied from below. The hot discharge air must always be discharged from the top (chimney effect).

6 | TIPS AND HELP

PROBLEM	POSSIBLE CAUSE	SUGGESTED SOLUTION
Appliance is not working.	There is no power supply to the appliance.	Check the appliance power supply.
	Cable or power supply unit is faulty.	Contact a service employee at Hartmann Tresore AG*.
	Fault in the electronics	Contact a service employee at Hartmann Tresore AG*.
Appliance has a poor cooling performance.	The room temperature is not in the optimum range.	Adapt the room temperature accordingly.
	The door has been opened too often.	Try to reduce the number of times the door is opened.
	The appliance door does not close properly.	See the section "The door does not close properly."
	The temperature controller is not set properly.	Set as required.
	The appliance has not been installed properly (wrong clearance dimensions).	Correct the clearance dimensions.
	The appliance has been exposed to heat or direct sunlight.	Position the appliance in a cool spot and avoid direct sunlight.
The interior lighting is not working.	There is no power supply to the appliance.	Check the appliance power supply.
	The LED lighting is faulty.	Contact a service employee at Hartmann Tresore AG*.
The door does not close properly.	The door hinge has not been installed correctly.	Correct the installation in accordance with section 6 (p. 10).
	The door seal is soiled.	Clean the door seal in accordance with section 9 (p. 13).
	The shelves, brackets or baskets are not in the correct position.	Adjust the components again.
Temperature control is not working.	Fault in the control electronics	Contact a service employee at Hartmann Tresore AG*.

*Tel. +49 (0)5251 1744-179 | Fax +49 (0)5251 1744-999 | Mail: support@hartmann-tresore.de



7 | CLEANING AND CARE



Warning! Danger to life!

- Always disconnect the appliance from the power supply before carrying out any cleaning work.
-



Please note! Risk of damage!

- Never clean the appliance under running water
 - Do not use any strong detergents or hard objects for cleaning.
-
- Please use a soft cloth and mild household detergent to clean the inside and outside of the appliance before putting it into operation. Do not use soap or aggressive cleaning agents for cleaning.
 - Make sure that the appliance seals do not come into contact with grease or grease-like substances.
 - Rub the seals and hinges with talcum powder from time to time. This guarantees that they will remain supple and have a long service life.
 - Please clean dust and any other dirt off the back of the appliance once a year in order to guarantee proper appliance function.

8 | SAVING ENERGY

- The appliance should not be set up in direct sunlight or near a source of heat (e.g. radiator). Use an insulating panel if necessary.
- Set the appliance up in a dry, ventilated room.
- Only open the appliance briefly to take things out.
- Fill the appliance with pre-cooled beverages if possible.
- Clean the back of the appliance occasionally.



9 | DISPOSAL

PLEASE NOTE!

This appliance is marked in accordance with the European Directive 2002/96/EC on waste electrical and electronic equipment!

The appliance packaging is made of reusable materials!

- The correct separate collection of these appliances and its eco-friendly treatment and disposal contribute to preventing potential negative impact on the environment and health.
- The packaging materials can be hazardous for children. For this reason, keep these materials out of the reach of children and dispose of them in accordance with the waste instructions.
- Do not dispose of the packaging materials together with normal waste.
- If necessary, contact your authorised sales agent or the waste collection centre in your region for information on disposing of your minibar.
- Remove the mains plug and any locks before disposal to protect children from possible hazards.

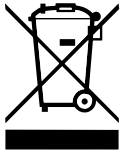

This symbol, which you can see on the product itself and in the product documents, means that the minibar must not be disposed of with normal household waste. The product must be taken to a special waste collection centre to guarantee the regulation-compliant disposal required for electronic appliances. If necessary, contact the waste collection centre or your sales agent for further information.

10 | GUARANTEE

The guarantee period begins with product purchase and lasts 12 months.



Please note! The guarantee is rendered invalid if

- the installation and operating instructions are not followed correctly and lead to malfunctions.
- the appliance is modified in any way.
- no original spare parts are used.

The guarantee is not applicable for any personal injury or property damage caused by non-observance of the operating manual or incorrect use of the appliance.

IMPORTANT: Product characteristics may be changed without advance notice.



Mit Sicherheit gut aufgehoben.



www.hartmann-tresore.de

HARTMANN TRESORE AG

Pamplonastraße 2
33106 Paderborn
Deutschland

+49 (0)5251 1744-179
support@hartmann-tresore.de